

ARCHI BOND GRAPHS IN A UNIFIED REPRESENTATION FOR BUILDING DESIGN

John S Gero and Jerry Jen-Hung Tsai

{john, jtsa4269}@arch.usyd.edu.au

Key Centre of Design Computing and Cognition

University of Sydney, Australia

ABSTRACT

This paper presents the development of a qualitative and quantitative energy-based representation for building design called Archi Bond Graphs which can be applied in the conceptual and final design stages of building design to represent both static and dynamic aspects of buildings.

Keywords: Archi Bond Graphs, building design, energy-based representation

INTRODUCTION

A building is a complex combination of elements and processes and can be viewed as a system. It integrates a variety of constructs including spatial layout, circulation arrangement, and energy movement and distribution, i.e., electricity, hydraulics, conditioned air, thermal energy, light energy, sound energy and communications. Each of these constructs is a subsystem of the building system. Different representations are used for different subsystems when designers develop a building design. Currently, there is no unified representation of building design which can represent different building constructs simultaneously. Especially, there is no unified representation of building design for representing three of the major aspects of a building: as a collection of objects, as a collection for people and their goods, and as a container and transformer of processes. There is also no adequate representation which can be applied in both the conceptual and final stages of building design. Most mature representations are used in the final stages of building design, CAD systems for instance. Representations for the conceptual stages of building design are still immature. There are few if any representations that can represent both qualitative and quantitative aspects of a building as well as few if any representations that can represent both static aspects such as spatial topologies and dynamic aspects such as people flow, goods flow and energy flow within buildings. There is a need, therefore, to develop a unified representation to allow designers to better utilise computational support tools during the early stages of design development.

The unified representation of building design that we are developing called Archi Bond Graphs (Gero and Tsai, 2004) is a qualitative and quantitative energy-based representation. Archi Bond Graphs can represent both static and dynamic aspects of buildings and can be applied in the conceptual and final building design stages. Current research into qualitative feature-based representation and modelling for

architectural design focuses on the qualitative aspects of shapes, objects and internal organization of architectural plans (Gero and Park, 1997, Gero and Damski, 1999, Gero and Jupp, 2002, Gero and Jupp, 2003). Archi Bond Graphs based on the concepts and characteristics of bond graphs can represent a building's qualitative aspects, such as spatial topology and topologies of different building energy arrangements, by a set of unified variables and elements. It is then augmented by quantitative data to represent people flow and building energy flow within the topologies.

This paper commences with the development of a qualitative and quantitative energy-based representation based on bond graphs which are extended to bond graphs for multiple domains (MBG). It then focuses on the architectural domain to produce Archi Bond Graphs (ABG). A preliminary application of Archi Bond Graphs is presented in this paper.

SYSTEM REPRESENTATION AND BOND GRAPHS

System representations can be drawings, graphs, bond graphs, block diagrams and sets of equations (Thoma, 1990). As we move from drawings to equations, so the representations become more abstract. Within a system representation, drawings can be converted into graphs and then bond graphs. The bond graph itself also embodies equations.

Bond graphs introduced by Henry Paynter in the early 1960's (Thoma, 1975, 1990, Gawthrop and Smith, 1996) are a class of graphical languages and systematic representations which provide a unified approach to the modelling and analysis of the dynamics of hybrid multi-domain systems. As a modelling tool, bond graphs can be used in the conceptual design stage. Bond graphs consist of variables, elements and constitutive relations, Figure 1. In the bond graph formalism, the determination of the input and output sets is defined as a causality assignment procedure. Bond graphs have been applied in many physical domains, such as mechanics, electronics and hydraulics, for the modelling of energy transfer and transformation behaviours. Further applications include modelling non-energy systems, such as economics, called pseudo bond graphs.

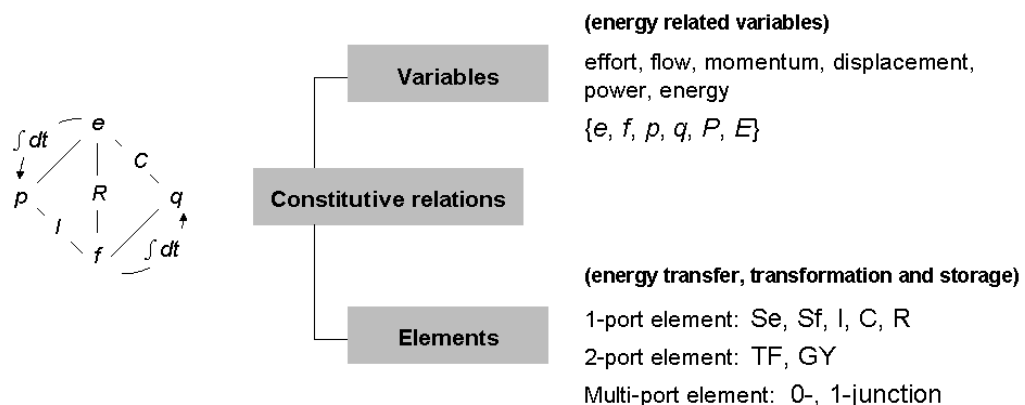

Figure 1 Variables, elements and constitutive relations of bond graphs

Rivard and Fenves (2000) state that a representation for the conceptual design of buildings should be able to integrate multiple views, support design evolution, favour design exploration and be extendable. Bond graphs are able: to reveal the relationships among the system, subsystems, and elements; to utilise physical qualitative information; to represent the topology of subsystems or elements of different physical domains; to represent the relationships of their products among them; to represent dynamic systems; and are flexible and extendable (Gero and Tsai, 2004). Therefore, bond graphs can be selected as a foundation for the development of a representation in the domain of architecture for buildings and their uses. This representation will be able to represent buildings through multiple views directly and have the capacity to represent the integration of a number of building constructs. So far, the applications of bond graphs in architecture have been limited to greenhouse dynamic modelling (Bot and van Dixhoorn, 1978) and HVAC systems design and simulation (Zeiler, 1997).

THE DEVELOPMENT OF ARCHI BOND GRAPHS

The development of a qualitative and quantitative energy-based representation for building design called Archi Bond Graphs (ABG) based on bond graphs commences with the development of bond graphs for multiple domains (MBG) and then focuses on the domain of architecture, Figure 2. ABG are then applied for representing spatial topology, people flow and energy arrangement topology and energy flow.

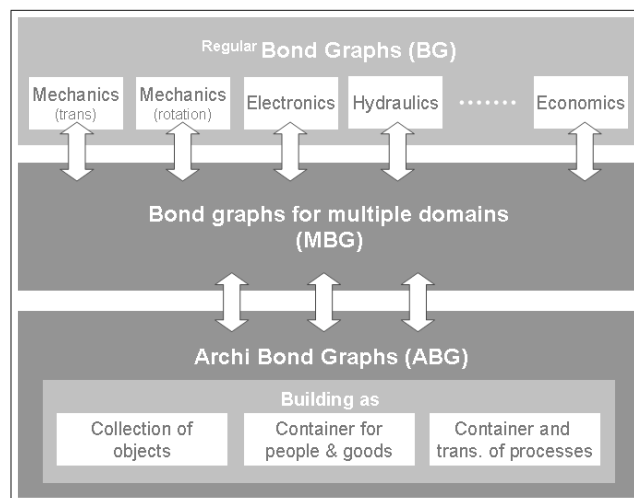

Figure 2 Development from bond graphs to Archi Bond Graphs

Bond graphs for multiple domains (MBG)

An MBG is a bond graph which has the capacity to integrate and be applied in multiple domains. In MBG we define energy, E , in a broad sense as that which has the ability and/or power to do or achieve something. The definition of displacement, q , is change by energy in a general sense. The other variables developed are:

- effort, e , is the amount of energy that is needed for a unit of change;
- flow, f , is the number of changes that happen in a unit of time;
- momentum, p , is the time integral of e , which is the amount of energy that is needed in a period of time for a unit of change; and

- power, P , the effort variable times the flow variable, is the time differential of energy.
- I-, C- and R-element are:
- I-element is the unit of flow that can cause or store an amount of energy in a period of time;
 - C-element is the unit of effort that can cause or store an amount of changes; and
 - R-element is the unit of flow that an amount of effort needs.

Archi Bond Graphs (ABG)

The development of ABG based on MBG commences with the development of ABG for people flow within buildings and defining variables of energy and displacement as:

Energy, E : people energy is the sum of all sub-amounts of energy consumed by all sub-groups of people moving within buildings; people, distance and importance are three parameters of energy.

Displacement, q : people change is the total number of people changes within a building during a period of time.

The variables of effort, flow, momentum and power of ABG for representing people flow within buildings are as follows:

Effort, e : unit people energy is the average amount of energy consumed by one person moving within a building.

Flow, f : people flow is the total number of people changes in a unit of time.

Momentum, p : people impulse is the average amount of energy consumed by one person moving within a building during a period of time. People impulse is the time integration of people energy, $p = \int edt$.

Power, P : people energy flow is the total amount of energy consumed by all people moving within a building in a unit of time. People energy flow is equal to unit people energy times people flow, $P = e \times f$.

Further, for the ABG I-, C- and R-elements are defined and the ABG Rd-element is introduced as follows:

I-element: let I be *space potential* which stores people impulse and pushes people to move within the building. The ABG I-element equals people impulse over people

flow, $I = \frac{p}{f} = \frac{\int edt}{f}$. People consume energy when they move within the building.

The ABG I-element represents *passages* such as corridors, ramps, steps and stairs. Passages within the building store people impulse and pushes people to move to other spaces within the building.

C-element: let C be *space capacitor* which treats space within a building as a container of people. It equals people divided by unit people energy, $C = \frac{q}{e} = \frac{\int fdt}{e}$.

The ABG C-element represents different types and scales of *rooms*. People with different motivations move between rooms with different functions.

R-element: let R be *space resistance* which represents the restrictions that affect people to move between spaces within the building.

Although ABG R-elements restrict people flow within buildings, people energy is not being consumed because of it. Therefore, the ABG Rd-element is introduced for this

particular character of ABG R-element.

Rd-element: represents *doors* within buildings which reduce people's flow speed or prevents people's movement but does not consume people energy. The difference between ABG Rd-element and R-element in bond graphs is that the Rd-element does not dissipate energy.

The ABG 0- and 1-junctions are treated as *space junctions*.

0-junction: is the space junction that connects one space to other spaces, people may move to different from the space they came. Elements, such as I-, C-, R- and Rd-element, are attached to an ABG 0-junction. All unit people energy (e) on the bonds between elements and this ABG 0-junction are equal, $e_1 = e_2 = e_3 = \dots = e_n$ ($n \in N, N$ is the number of bonds connected to this 0-junction), and the sum of people flow (f) is zero, $\sum f = 0$.

1-junction: is the space junction that connects one space to other spaces, where people are not be able to move to other spaces except move back to the space from which they came. All people flow (f) on the bonds between elements and this ABG 1-junction are equal, $f_1 = f_2 = f_3 = \dots = f_n$ ($n \in N, N$ is the number of bonds connected to this 0-junction), and the sum of unit people energy (e) is zero, $\sum e = 0$.

Table 1 shows variables and elements of ABG for representing spatial topology and people flow of building design.

TABLE 1 Variables and elements of ABG

□ Variables of ABG		□ Elements of ABG	
Effort, e	unit people energy	I-element	space potential
Flow, f	people flow	C-element	space capacitor
Momentum, p	people impulse	R-element	space resistance
Displacement, q	people (people change)	Rd-element	
Power, P	people energy flow	0- & 1-junction	space connection
Energy, E	people energy		

Causality in bond graphs establishes the cause and effect relationships between the factors of power, which are effort and flow. In each bond, the input and output are characterized by the causal stroke. The causal stroke represents the place where flow moves away from and effort moves into. We extend the concept of the bicausal bond, introduced by Gawthrop (1995), to develop the ABG bicausal bond. The ABG bicausal bond for representing people flow within buildings has the capacity to represent both people flow into and out of spaces simultaneously as well as representing the energy people consume when they move between spaces within the building, Figure 3. This differs from bond graphs developed so far which consist of only one pair of effort and flow associated with a bond.

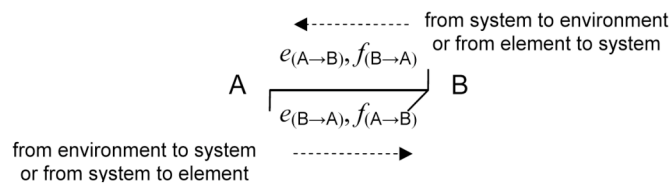

Figure 3 ABG bicausal bond

An ABG can also represent goods flow within buildings. In such an ABG goods are a factor of the energy variable, E , which replaces people in ABG. Energy of goods flow within buildings is represented as goods energy. An ABG applied to the building as a container and transformer of energy related processes is still under development.

ABG application

We will use an ABG to represent the qualitative aspects of spatial topology and illumination arrangement topology of a floor. Then by assigning quantitative data we can examine people flow and electrical energy flow for illumination as well as their interrelationships.

Figures 4 and 5 are the plan and the spatial topology of the townhouse ground floor respectively. Figure 6 shows the simplified illumination arrangement plan related to the spatial plan of this townhouse ground floor. It is divided into a number of zones. Switches in the illumination arrangement plan can be treated as an analogy to doors in spatial plan and control electric energy flow of illumination in or out the circuits in different zones.

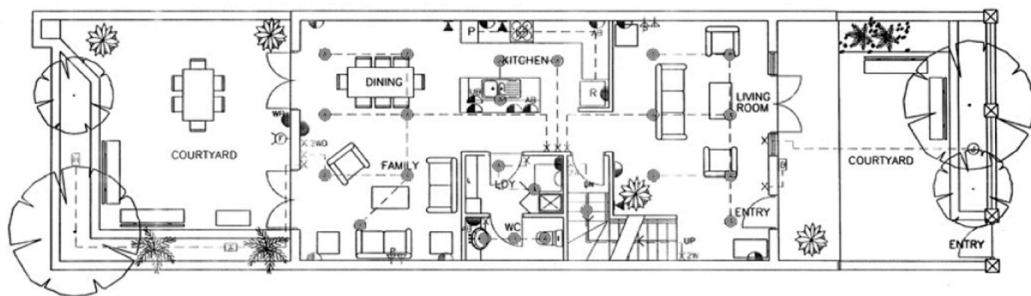

Figure 4 A design drawing of townhouse ground floor plan

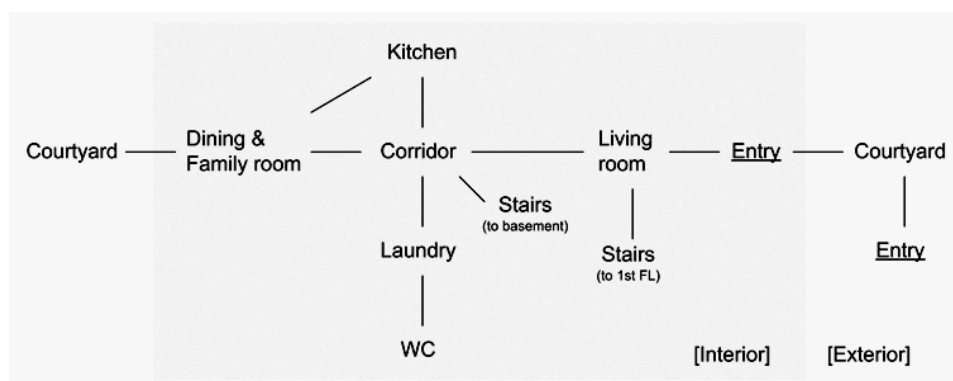

Figure 5 Spatial topology of townhouse ground floor

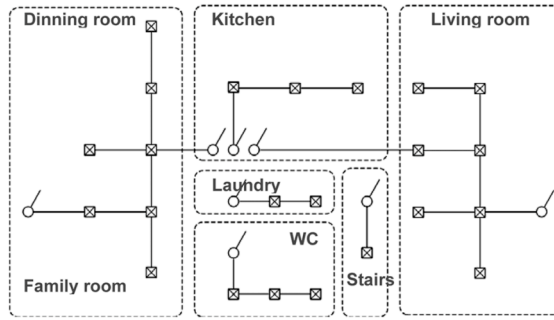
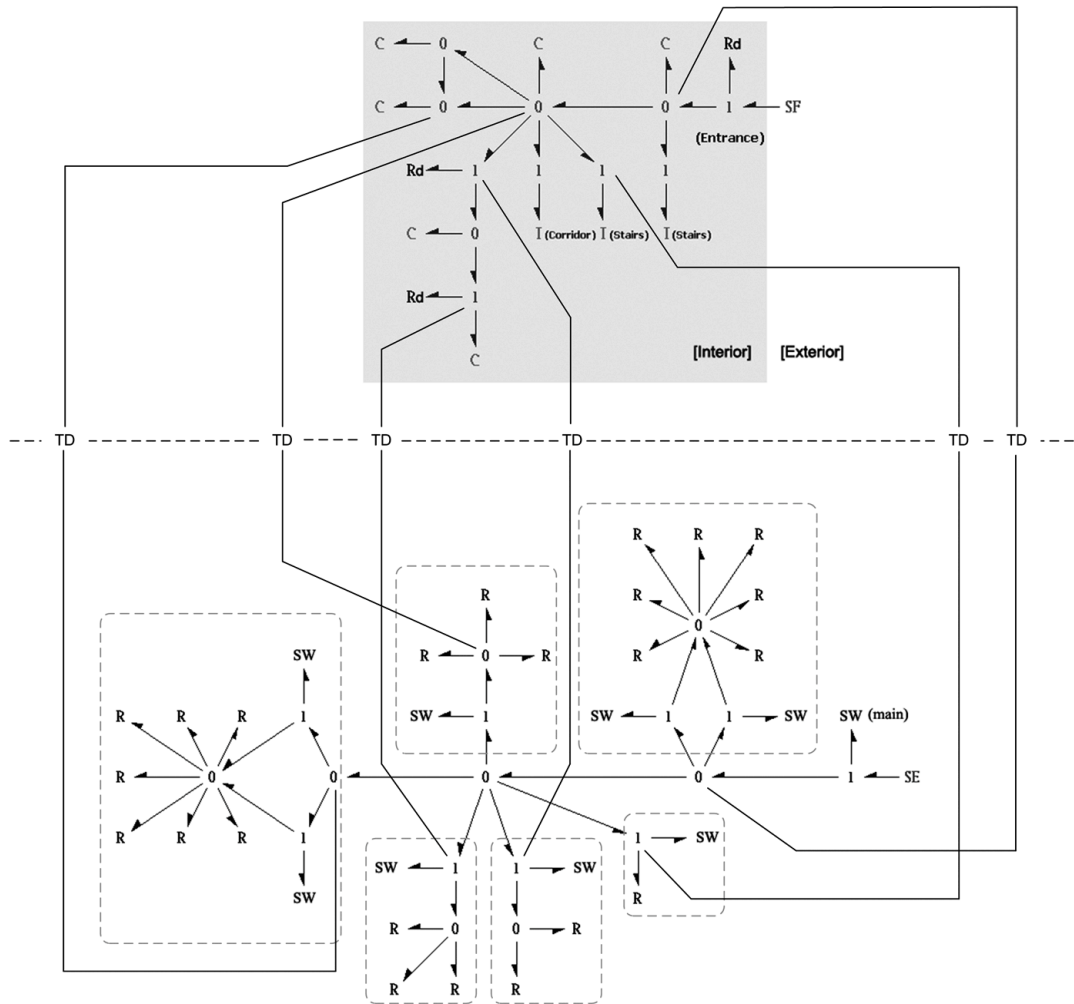

Figure 6 Simplified illumination arrangement plan of townhouse ground floor

The ABG utilizes a set of unified variables and elements to represent spatial topology, people flow and energy arrangement topology and energy flow. Two subsystems, spatial topology relating to people flow and illumination arrangement topology relating to electric energy flow, are presented in two different layers. These can be put together to represent their energy transfer and transformation, Figure 7.

[Spatial topology / people flow]



[Illumination arrangement topology / electric energy flow]

TD: Energy transducer
 — : Energy transfer and transformation

Figure 7 ABG representing energy transfer and transformation between two constructs of building design

An ABG representing the ground floor spatial topology is shown on the top of Figure 7. Within it, people move through the entrance into the building. Physically, there is no wall between the dining room and family room. It is a single space. Applying an ABG for representing people flow within this floor, the dining and family rooms are divided into two spaces since the ABG is capable of representing people flow and people energy transfer/transformation in different functional spaces within the building. SF is the source of people flow and is the main starting point of people flow. Stairs and corridor are I-elements which stand for spatial potential and store people impulse, and then push people to move to other spaces/rooms within the building. Living room, kitchen, dining and family rooms are C-elements. They are containers of people which relate to people energy.

The ABG representing the illumination arrangement topology of the townhouse ground floor is on the bottom of Figure 7. SE of illumination system is the source of illumination electric energy which moves through the main switch into the ground floor illumination arrangement. SW represents switches and R represents light settings or light bulbs which consume electric energy. The 0-junctions and 1-junctions are parallel-junctions and serial-junctions respectively.

Tables 2 and 3 show the ABG variables and elements of people and illumination system energy and flow respectively. The number of people moving between spaces/rooms within the building is a variable. The energy consumption will be then affected by the number of people change. The larger the amount of people flow (f), the larger the amount of energy effort (e) required. TD in Figure 7 is a transducer representing the mechanism where different types of energy are transformed. People move between spaces, especially when there is no natural light, artificial illumination will be needed and this causes illumination electric energy consumption. The interrelationship between people energy and illumination electric energy can be represented as

$$\text{people energy} = k \cdot \text{electric energy} \quad (k > 0) \quad (1)$$

Therefore, based on people energy, people flow and their transformations through transducers we are then being able to measure and estimate electric energy consumption of illumination.

Table 2 The ABG variables of people energy and flow and illumination system

Variables	Energy	People	Illumination / Electrics
Effort, e		Unit people energy	Voltage
Flow, f		People flow	Current
Momentum, p		People impulse	Flux linkage
Displacement, q		People (people change)	Charge
Power, P		People energy flow	Power
Energy, E		People energy	Energy

Table 3 The ABG elements of people energy and flow and illumination system

Elements	Energy	People	Illumination / Electrics
I-element		Passage, Spatial potential	Inductor
C-element		Room, Spatial capacitor	Capacitor
R-element		Spatial resistance	Light setting
Control		Door	Switch

CONCLUSION AND FUTURE WORK

This paper presents the preliminary stage of developing a unified representation for building design which is a qualitative and quantitative energy-based representation called Archi bond Graphs (ABG). The ABG is a graphical representation which also embodies equations. By applying a set of unified variables, elements, and following their constitutive relations, an ABG provides a simple and unified mechanism for designers to design and exam the interrelationships between people and different energy needed in various spatial/energy arrangements. It enables the discussion of energy transfer and transformation between different kinds of energy in the same platform.

ABG representation can be an analytic tool for building design. Based on different purposes and/or requirements, designers can identify specific layers, put the layers together and integrate them into a system to discuss interactions among them. When a component and/or a power value is changed in one layer, the related components in the same layer and in different layers will respond and change accordingly. As a consequence, designers are able to formulate and evaluate their designs more precisely and quickly than before. Preliminary ABG applications for building design, people energy, people flow, illumination system, and their energy transfer and transformation have been presented in this paper. Other building constructs/aspects, such as water supply system, hydronic heating system, electric system, cooling air, will be included in further development of ABG representation for building design.

People and energy flows within a building can be through walls, through space/spatial interconnections and/or through restricted paths, such as doors, pipes and cables. They can move continuously or discontinuously. Future work in the development and application of the ABG will focus on the flow of people and different types of energy moving through their particular paths to particular zones as compared to simply representing the spatial layout. It will also focus on building construction systems and facilities which affect energy consumption. With the assistance of the concept of inverse kinematics, an ABG will also be developed to provide a method to compute and represent the interactions across different layers in a system when one layer is changed. In this way the unified representation of building design can be fully completed.

REFERENCES

- Bot, G. P. A. and van Dixhoorn, J. J. (1978) "Dynamic modelling of greenhouse climate using a minicomputer", *ISHS Acta Horticulturae*, Vol. 76, pp. 113-120.
- Gawthrop, P. J. (1995) "Bicausal bond graphs", *International Conference on Bond Graphs Modeling and Simulation (ICBGM'95)*, Society for Computer Simulation, Las Vegas, pp. 83-88.
- Gawthrop, P. J. and Smith, L. (1996) *Metamodelling: for Bond Graphs and Dynamic Systems*, Prentice Hall, London.
- Gero, J. S. and Damski, J. C. (1999) "Feature-based qualitative modeling of objects", In G. Augenbroe and C. Eastman (Eds), *Computers in Building*, Kluwer, Boston, pp. 309-320.
- Gero, J. S. and Jupp, J. (2002) "Measuring the information content of architectural plans", In P. L. Hippolyte and E. Miralles (Eds), *SIGraDi Caracas 2002*, Ediciones Universidad Central de Venezuela, Caracas, pp. 155-158.
- Gero, J. S. and Jupp, J. (2003) "Feature-based qualitative representation in architectural plans", In A. Choutgrajank, E. Charoenslip, K. Keatruangkamala and W. Nakapan (Eds), *CAADRIA 2003*, Rangsit University, Bangkok, pp. 117-128.
- Gero, J. S. and Park, S.-H. (1997) "Computable feature-based qualitative modeling of shape and space", In R. Junge (Ed.) *CAAD Futures 1997*, Kluwer, Dordrecht, pp. 821-830.
- Gero, J. S. and Tsai, J. (2004) "Application of bond graph models to the representation of buildings and their use", In H. Lee and J. Choi (Eds), *CAADRIA 2004*, Yonsei University Press, Seoul, pp. 373-385.
- Rivard, H. and Fenves, S. J. (2000) "A representation for conceptual design of building", *Journal of Computing in Civil Engineering*, Vol. 14, pp. 151-159.
- Thoma, J. U. (1975) *Introduction to Bond Graphs and Their Applications*, Pergamon Press, Oxford.
- Thoma, J. U. (1990) *Simulation by Bondgraphs: Introduction to a Graphical Method*, Springer-Verlag, Berlin.
- Zeiler, W. (1997) "Design and simulation of HVAC systems with bond graphs", *Proceedings of Building Simulation '97*, pp. 251-259.

This is a copy of the paper: Gero, JS and Tsai, J (2005) Archi bond graphs in a unified representation for building design, in S Sariyildiz and B Tuncer (eds), *Innovation in Architecture, Engineering and Construction*, Delft University of Technology, Delft, pp. 577-587.